

## Fig.IN 40NGT

PN10 nodulair gietijzeren terugslagklep met scharnierende klep, GGG-40 huis, rvs 1.4301 klep met teflon dichting, volle doorlaat, flenzen PN10, Fig.IN 40NGT.

PN10 swing type check valve, nodular cast iron GGG-40 body, 1.4301, PTFE seated, full bore, flanged PN10, Fig.IN 40NGT.

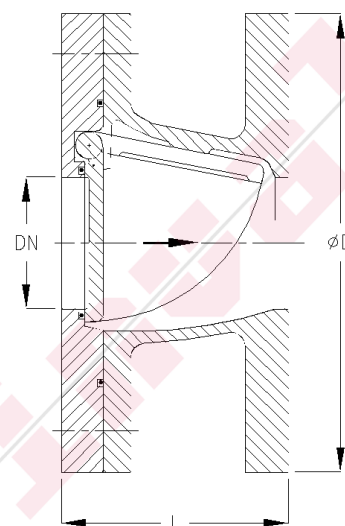

### OPMERKINGEN / REMARKS

Doorlaat Bore	Drukklasse Pressure rating	Max. werkdruk Max. working pressure
------------------	-------------------------------	--

DN 15-150	PN 16	16 bar
DN 200-300	PN 10	10 bar

Optional seals:

EPDM	-50°C +130°C	NBR	-30°C +100°C	Viton	-15°C +200°C
------	--------------	-----	--------------	-------	--------------

### MATERIAAL / MATERIAL

Huis / Body	Nodulair gietijzer / Nodular cast iron	GGG-40	GJS-400-15	JS-1030 / Ø.7040
Zitting / Seat	PTFE / PTFE			
Klep / Disc	Roestvast staal / Stainless steel	AlSi 304	X5CrNi18-9	1.4301

### AFMETINGEN / DIMENSIONS

DN	15	20	25	32	40	50	65	80	100	125	150								
L	65	65	70	75	80	85	105	125	145	170	200								
ØD	95	105	115	140	150	165	185	200	220	250	285								
PCD	65	75	85	100	110	125	145	160	180	210	240								
nxd	4x14	4x14	4x14	4x18	4x18	4x18	4x18	8x18	8x18	8x18	8x22								
Kilo	2	2,3	3	4,1	4,9	6,1	8	9,7	13,5	18	25								