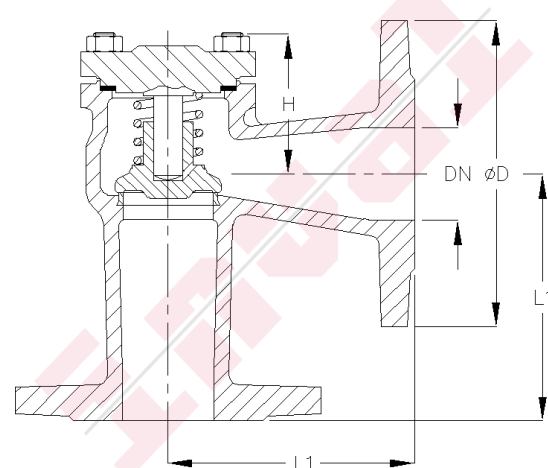

Fig.IN 295

PN40 haakse GS-C25 terugslagklep, RVS 304 dichting, op en neergaande klep, veerbelast, flenzen en boring PN40, Fig.IN 295.

PN40 angle piston type check valve, cast steel GS-C25 body and bolted cover, AISI 304 seats, spring loaded, flanged PN40, Fig.IN 295.



OPMERKINGEN / REMARKS

MATERIAAL / MATERIAL

|                 |                                   |          |            |        |
|-----------------|-----------------------------------|----------|------------|--------|
| Huis / Body     | Staal / Steel                     | GS-C25   | GP240GH    | 1.0619 |
| Deksel / Bonnet | Staal / Steel                     | GS-C25   | GP240GH    | 1.0619 |
| Zitting / Seat  | Roestvast staal / Stainless steel | AISI 304 | X5CrNi18-9 | 1.4301 |
| Klep / Disc     | Staal / Steel                     | GS-C25   | GP240GH    | 1.0619 |
| Veer / Spring   | Roestvast staal / Stainless steel | AISI 304 | X5CrNi18-9 | 1.4301 |

AFMETINGEN / DIMENSIONS

|      |      |      |      |      |      |      |      |      |      |      |      |      |      |       |       |       |       |       |       |  |
|------|------|------|------|------|------|------|------|------|------|------|------|------|------|-------|-------|-------|-------|-------|-------|--|
| DN   | 15   | 20   | 25   | 32   | 40   | 50   | 65   | 80   | 100  | 125  | 150  | 175  | 200  | 250   | 300   | 350   | 400   | 450   | 500   |  |
| L1   | 90   | 95   | 100  | 105  | 115  | 125  | 145  | 155  | 175  | 200  | 225  | 250  | 275  | 325   | 375   | 425   | 475   | 500   | 525   |  |
| ØD   | 95   | 105  | 115  | 140  | 150  | 165  | 185  | 200  | 220  | 250  | 285  | 315  | 340  | 395   | 445   | 505   | 565   | 615   | 670   |  |
| H    | 55   | 55   | 60   | 60   | 75   | 75   | 80   | 90   | 105  | 115  | 130  | 150  | 155  | 170   | 210   | 250   | 270   | 330   | 360   |  |
| PCD  | 65   | 75   | 85   | 100  | 110  | 125  | 145  | 160  | 180  | 210  | 240  | 270  | 295  | 350   | 400   | 460   | 515   | 565   | 620   |  |
| nxd  | 4x14 | 4x14 | 4x14 | 4x18 | 4x18 | 4x18 | 4x18 | 8x18 | 8x18 | 8x18 | 8x22 | 8x22 | 8x22 | 12x22 | 12x22 | 16x22 | 16x26 | 20x26 | 20x26 |  |
| Kilo | 3    | 3,5  | 4    | 6    | 8    | 10   | 14   | 19   | 25   | 45   | 70   | 93   | 112  | 153   | 190   | 220   | 290   | 340   | 480   |  |