



appendages en instrumenten voor
scheepsbouw en industrie
valves for shipbuilding and industry

Inval Industrial Valves Holland B.V.
Buitendijks 5 3356 LX Papendrecht
Telefoon +31 (0)78 - 641 15 00
E-mail info@invalholland.com
Website www.invalholland.com

Fig.IN 294

PN40 rechte GS-C25 terugslagklep, RVS 304 dichting, op en neergaande klep, veerbelast, flenzen en boring PN40, Fig.IN 294.

PN40 straight piston type check valve, cast steel GS-C25 body and bolted cover, AISI 304 seats, spring loaded, flanged PN40, Fig.IN 294.

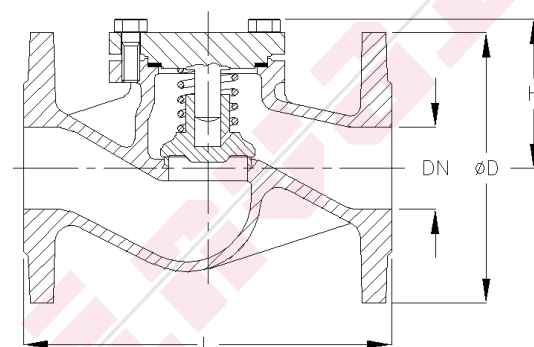

OPMERKINGEN / REMARKS

MATERIAAL / MATERIAL

Huis / Body	Staal / Steel	GS-C25	GP240GH	1.0619
Deksel / Bonnet	Staal / Steel	GS-C25	GP240GH	1.0619
Zitting / Seat	Roestvast staal / Stainless steel	AISI 304	X5CrNi18-9	1.4301
Klep / Disc	Staal / Steel	GS-C25	GP240GH	1.0619
Veer / Spring	Roestvast staal / Stainless steel	AISI 304	X5CrNi18-9	1.4301

AFMETINGEN / DIMENSIONS

DN	15	20	25	32	40	50	65	80	100	125	150	175	200	250	300	350	400	450	500	
L	130	150	160	180	200	230	290	310	350	400	480	550	600	730	850	980	1100	1200	1250	
ØD	95	105	115	140	150	165	185	200	220	250	285	315	340	395	445	505	565	615	670	
H	55	55	65	75	80	85	95	115	140	160	200	225	245	290	345	400	425	450	500	
PCD	65	75	85	100	110	125	145	160	180	210	240	270	295	350	400	460	515	565	620	
nxd	4x14	4x14	4x14	4x18	4x18	4x18	4x18	8x18	8x18	8x18	8x22	8x22	8x22	12x22	12x22	16x22	16x26	20x26	20x26	
Kilo	2,4	3	3,8	5,7	7,4	10,3	15,2	20,4	31	49	69	101	132	150	230	280	430	500	670	