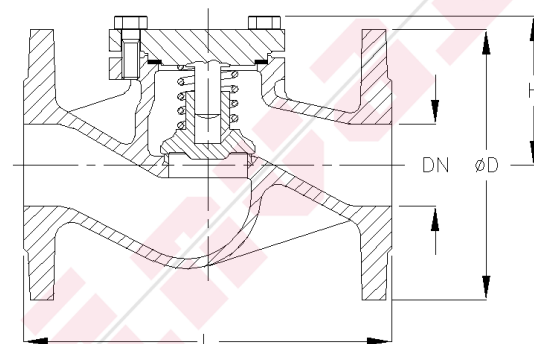

Fig.IN 290

PN10 rechte GG-25 terugslagklep, bronzen dichting, op en neergaande klep, veerbelast, flenzen en boring PN10, Fig.IN 290.

PN10 straight piston type check valve, cast iron GG-25 body and bolted cover, bronze Rg5 seats, spring loaded, flanged PN10, Fig.IN 290.



OPMERKINGEN / REMARKS

MATERIAAL / MATERIAL

Huis / Body	Gietijzer / Cast iron	GG-25	GLJ-250	JL-1040 / 0.6025
Deksel / Bonnet	Gietijzer / Cast iron	GG-25	GLJ-250	JL-1040 / 0.6025
Zitting / Seat	Bronz / Bronze	Rg 5	CuSn5Zn5Pb5-C	CC491K / 2.1096.01
Klep / Disc	Gietijzer / Cast iron	GG-25	GLJ-250	JL-1040 / 0.6025
Veer / Spring	Roestvast staal / Stainless steel	AlSi 304	X5CrNi18-9	1.4301

AFMETINGEN / DIMENSIONS

DN	15	20	25	32	40	50	65	80	100	125	150	175	200	250	300	350	400	450	500	
L	130	150	160	180	200	230	290	310	350	400	480	550	600	730	850	980	1100	1200	1250	
ØD	95	105	115	140	150	165	185	200	220	250	285	315	340	395	445	505	565	615	670	
H	55	55	65	75	80	85	95	115	140	160	200	225	245	290	345	400	425	450	500	
PCD	65	75	85	100	110	125	145	160	180	210	240	270	295	350	400	460	515	565	620	
nxd	4x14	4x14	4x14	4x18	4x18	4x18	4x18	8x18	8x18	8x18	8x22	8x22	8x22	12x22	12x22	16x22	16x26	20x26	20x26	
Kilo	2,4	3	3,8	5,7	7,4	10,3	15,2	20,4	31	49	69	101	132	150	230	280	430	500	670	