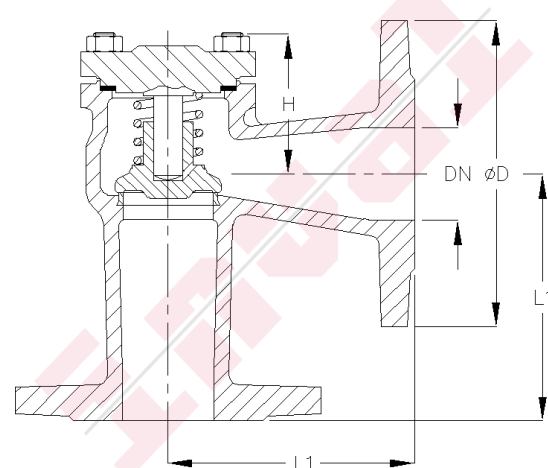

Fig.IN 289

PN10 haakse bronzen terugslagklep, integrale dichting, op en neergaande klep, veerbelast, flenzen en boring PN10, Fig.IN 289.

PN10 angle piston type check valve, bronze Rg5 body and bolted cover, integral seats, spring loaded, flanged PN10, Fig.IN 289.



OPMERKINGEN / REMARKS

MATERIAAL / MATERIAL

Huis / Body	Brons / Bronze	Rg 5	CuSn5Zn5Pb5-C	CC491K / 2.1096.01
Deksel / Bonnet	Brons / Bronze	Rg 5	CuSn5Zn5Pb5-C	CC491K / 2.1096.01
Klep / Disc	Brons / Bronze	Rg 5	CuSn5Zn5Pb5-C	CC491K / 2.1096.01
Veer / Spring	Roestvast staal / Stainless steel	AlSI 304	X5CrNi18-9	1.4301

AFMETINGEN / DIMENSIONS

DN	15	20	25	32	40	50	65	80	100	125	150	175	200	250	300	350	400	450	500	
L1	90	95	100	105	115	125	145	155	175	200	225	250	275	325	375	425	475	500	525	
ØD	95	105	115	140	150	165	185	200	220	250	285	315	340	395	445	505	565	615	670	
H	55	55	60	60	75	75	80	90	105	115	130	150	155	170	210	250	270	330	360	
PCD	65	75	85	100	110	125	145	160	180	210	240	270	295	350	400	460	515	565	620	
nxd	4x14	4x14	4x14	4x18	4x18	4x18	4x18	8x18	8x18	8x18	8x22	8x22	8x22	12x22	12x22	16x22	16x26	20x26	20x26	
Kilo	3	3,5	4	6	8	10	14	19	25	45	70	86	100	125	195	230	300	350	490	