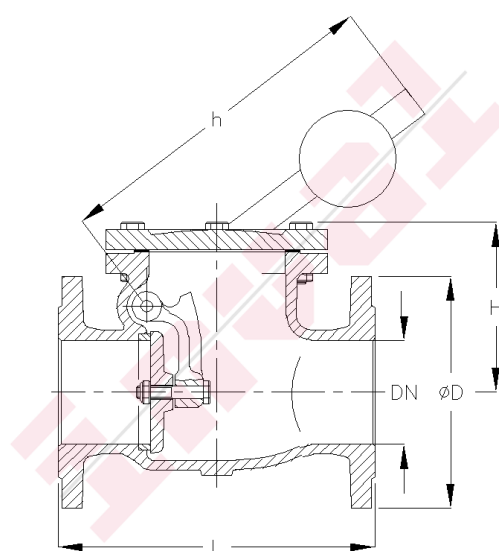

Fig.IN 174G

PN10 rechte GG-25 terugslagklep, scharnierende klep, hefboom en gewicht,
RVS 304 dichting, flenzen en boring PN10, Fig.IN 174G.

PN10 swing type check valve, cast iron GG-25 body and bolted cover,
stainless steel AISI 304 seats, weight loaded, flanged PN10, Fig.IN 174G.



OPMERKINGEN / REMARKS

MATERIAAL / MATERIAL

| | | | | |
|-----------------|--|----------|---------------|------------------|
| Huis / Body | Gietijzer / Cast iron | GG-25 | GLJ-250 | JL-1040 / 0.6025 |
| Deksel / Bonnet | Gietijzer / Cast iron | GG-25 | GLJ-250 | JL-1040 / 0.6025 |
| Zitting / Seat | Roestvast staal / Stainless steel | AISI 304 | X5CrNi18-9 | 1.4301 |
| Klep / Disc | Nodulair gietijzer / Nodular cast iron | GGG-40.3 | GJS-400-18 LT | JS-1025 / 0.7043 |
| As / Shaft | Roestvast staal / Stainless steel | AISI 420 | X20Cr13 | 1.4021 |

AFMETINGEN / DIMENSIONS

| DN | 40 | 50 | 65 | 80 | 100 | 125 | 150 | 200 | 250 | 300 | 350 | 400 | 500 | 600 | | | | | | |
|------|------|------|------|------|------|------|------|------|-------|-------|-------|-------|-------|-------|--|--|--|--|--|--|
| L | 180 | 200 | 240 | 260 | 300 | 350 | 400 | 500 | 600 | 700 | 800 | 900 | 1100 | 1300 | | | | | | |
| ØD | 150 | 165 | 185 | 200 | 220 | 250 | 285 | 340 | 395 | 445 | 505 | 565 | 670 | 780 | | | | | | |
| H | 100 | 105 | 120 | 145 | 155 | 165 | 190 | 290 | 300 | 365 | 420 | 485 | 580 | 700 | | | | | | |
| h | 200 | 200 | 300 | 300 | 300 | 400 | 400 | 500 | 500 | 600 | 670 | 900 | 1100 | 1100 | | | | | | |
| PCD | 110 | 125 | 145 | 160 | 180 | 210 | 240 | 295 | 350 | 400 | 460 | 515 | 620 | 725 | | | | | | |
| nxd | 4x18 | 4x18 | 4x18 | 8x18 | 8x18 | 8x18 | 8x22 | 8x22 | 12x22 | 12x22 | 16x22 | 16x26 | 20x26 | 20x30 | | | | | | |
| Kilo | 13 | 16 | 19 | 28 | 34 | 52 | 64 | 101 | 175 | 235 | 385 | 545 | 1030 | 1247 | | | | | | |